User's Manual

Model PR201 Power Monitor

POWERCERT

IM 77C01C01-01E

Blank Page

■ How to Install



NOTE

- (1) To install the product, select a location where:
 - no one may accidentally touch the terminals,
 - mechanical vibrations are minimal,
 - corrosive gas is minimal,
 - Ambient temperature: 0 to 50°C; Ambient humidity: 50 to 90%RH
And the fluctuation is minimal,
 - no direct radiant heat is present,
 - no magnetic disturbances are caused,
 - no wind blows against the terminal board (reference junction compensation element),
 - no water is splashed,
 - no flammable materials are around,
 - (2) Make sure to connect the grounding.
 - (3) Turn off the product before installation and wiring.
 - (4) Use the power supply within specifications.
 - (5) Observe the following instructions for correct installation:
Recommended panel thickness is 1 to 10mm.
Install the product horizontally.
Install the product using attached fixture from the backside of the product.
Turn the screw only up to 180° after the screw touches the mounting panel to prevent the case deformation by tightening the screw excessively.
 - (6) Observe the following instructions for correct wiring:
M3 screw terminal connection (output, communication, optional integrated control signal)
M4 screw terminal connection (input, power supply)
Applicable wire size for input signal and power supply is 1.25mm² or more of cross sectional area.
-

■ Model and Suffix Codes

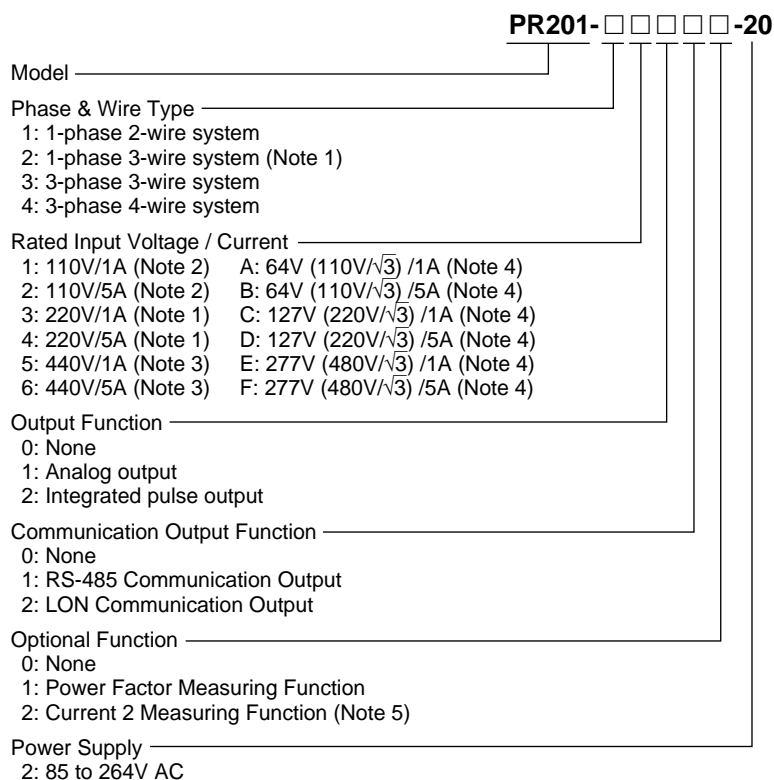

(Note 1) Input specs. of 1-phase 3-wire system can only select rated input 3 and 4. Input voltage is 200VAC (100V+100V).

(Note 2) Rated input 1, 2 (110V) can also be used at 120V input.

(Note 3) Rated input 5, 6 (440V) is the specs. only for 1-phase 2-wire system and 3-phase 3-wire system.

(Note 4) Rated input A to F is the specs. for only 3-phase 4-wire system. Rated input voltage indicates phase voltage.
A, B: 64V, C, D: 127V, E, F: 227V indicate $110V/\sqrt{3}$, $220V/\sqrt{3}$, $480V/\sqrt{3}$ respectively. In case of $440V/\sqrt{3}$ input, it can be used at E, F: 227V of rated input.

(Note 5) Specify this option when the previous style UZ005(S2.0) with option "Current 2 measuring Function" is required.

Current measuring object of current 2 measuring function:

1-phase 3-wire system : I_2 current r.m.s. value

3-phase 3-wire and 3-phase 4-wire system : I_3 current r.m.s. value



NOTE

Before using the product, check that its model and suffix codes as you ordered.

LIST OF COMBINATION OF PR201 RATED INPUT

Code	Rated Input	Phase & Wire System			
		1-phase 2-wire	1-phase 3-wire	3-phase 3-wire	3-phase 4-wire
1	110V/1A	○	—	○	○
2	110V/5A	○	—	○	○
3	220V/1A	○	○*	○	○
4	220V/5A	○	○*	○	○
5	440V/1A	○	—	○	—
6	440V/5A	○	—	○	—
A	64V/1A	—	—	—	○
B	64V/5A	—	—	—	○
C	127V/1A	—	—	—	○
D	127V/5A	—	—	—	○
E	277V/1A	—	—	—	○
F	277V/5A	—	—	—	○

○: Available —: Not available

*200V AC (100V+100V)

External Dimensions and Panel Cutout Dimensions

External Dimensions

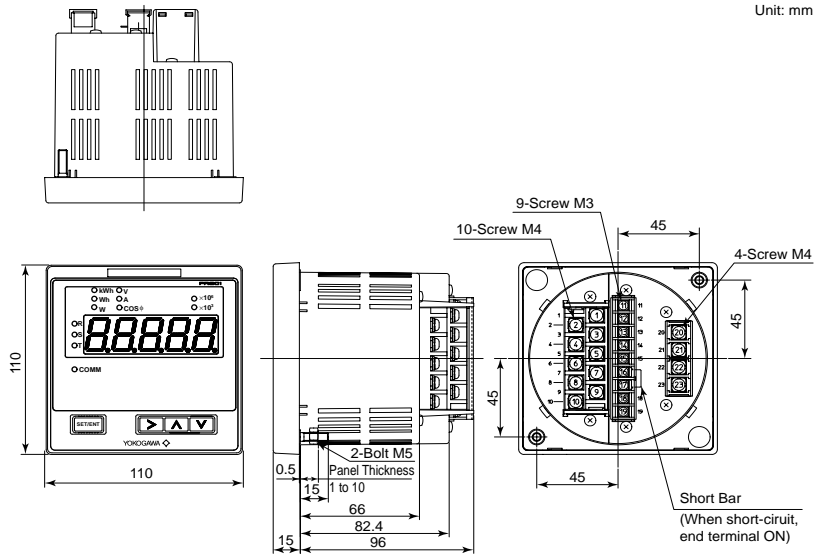

Panel Cut Dimension

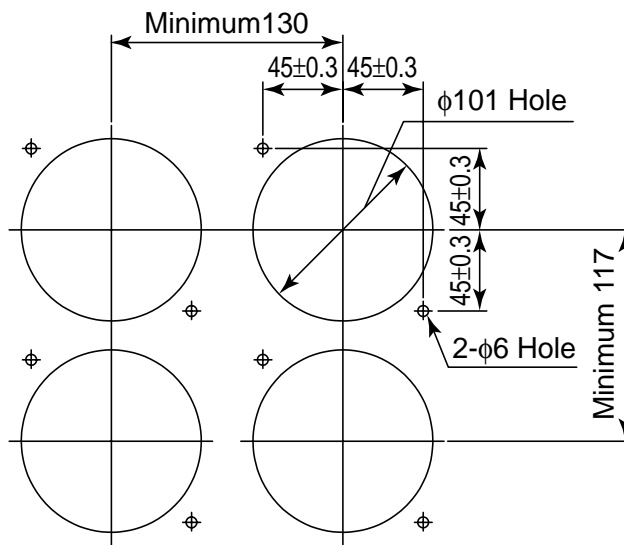

■ Mounting the Product



Turn off the power to the product before installing it on the panel because there is a possibility of electric shock.

After opening the mounting hole on the panel, follow the procedures below to install the product:

1. Insert the product into the opening from the front of the panel so that the terminal board on the rear is at the far side.
2. Set the brackets in place on the top and bottom of the product as shown in the figure below, then tighten the screws of the brackets. Take care not to overtighten them.

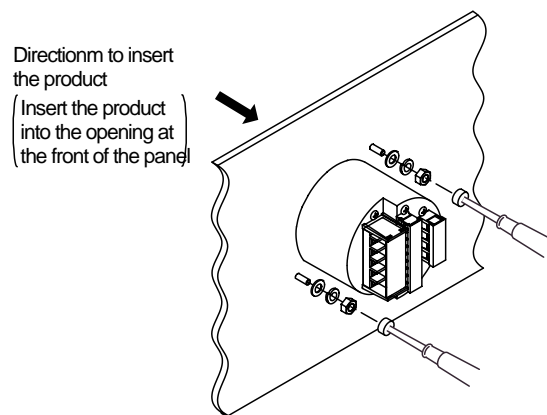

■ Terminal Arrangement

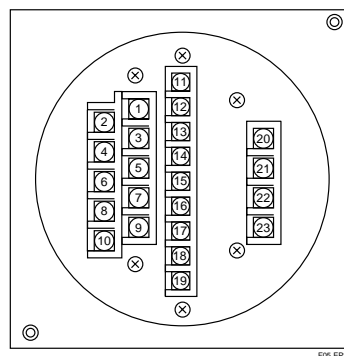

TML No.	Signal				
	1-phase 2-wire	1-phase 3-wire	3-phase 3-wire	3-phase 4-wire	
1	1S	1S	1S	1S	Input
2	1L	1L	1L	1L	
3		2S	3S	2S	
4		2L	3L	2L	
5				3S	
6				3L	
7	P1	P1	P1	P1	
8	P2	P0	P2	P0	
9		P2	P3	P2	
10				P3	
11	+				Output
12	-				
13	A				Communication
14	B				
15	C				
16					Communication Terminating
17					
18	+				Optional Integrated Control Signal
19	-				
20	L				Power Supply
21	N				
22					
23	GND				

T14.EPS

■ Wiring Diagrams

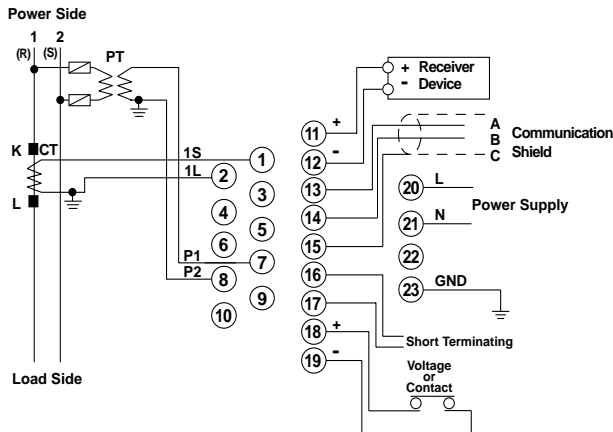

1 phase 2 wire system

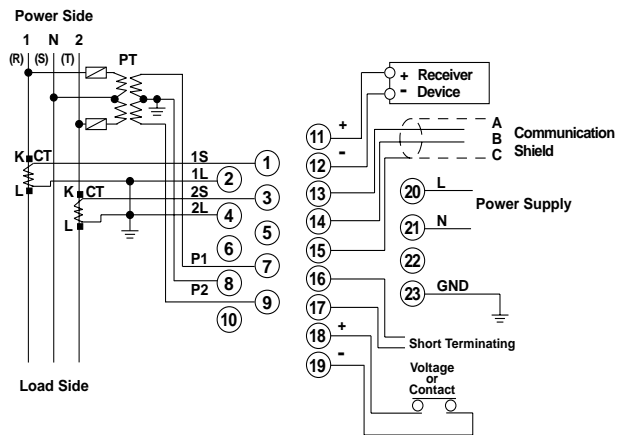

1 phase 3 wire system

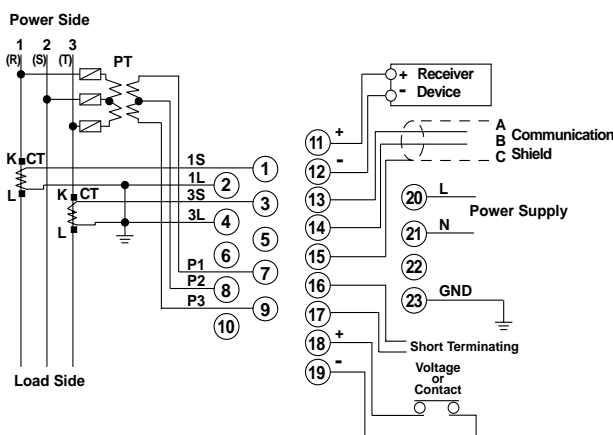

3 phase 3 wire system

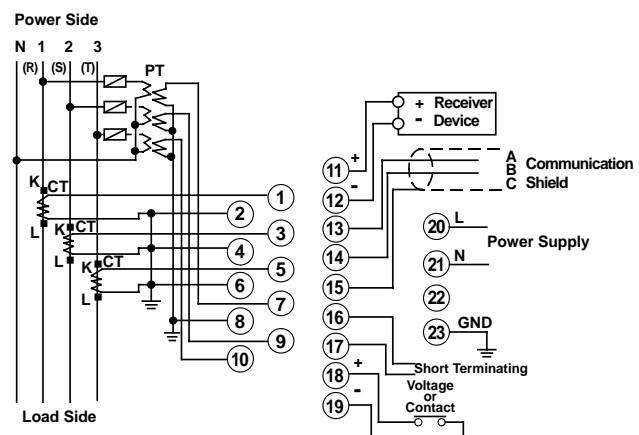

3 phase 4 wire system



The following caution for safety should be taken for handling of product. We are not responsible for damage incurred by use contrary to caution.

- The following items should be checked before turning power on. Use of product ignoring specifications may cause over heating or burning.
 - (a) Voltage of power supply and input value applied to the product should meet with required specifications.
 - (b) External wiring to terminals should be connected correctly.
(See preceding Article 4)
- When take off wiring from the product, check to see primary side of CT, PT and power supply is in OFF status. If CT secondary side is in OPEN status during operation, be careful for danger of high voltage.
- Do not use the product in such dangerous places where exist inflammable and explosive gas or steam.

■ Outline of Each Section

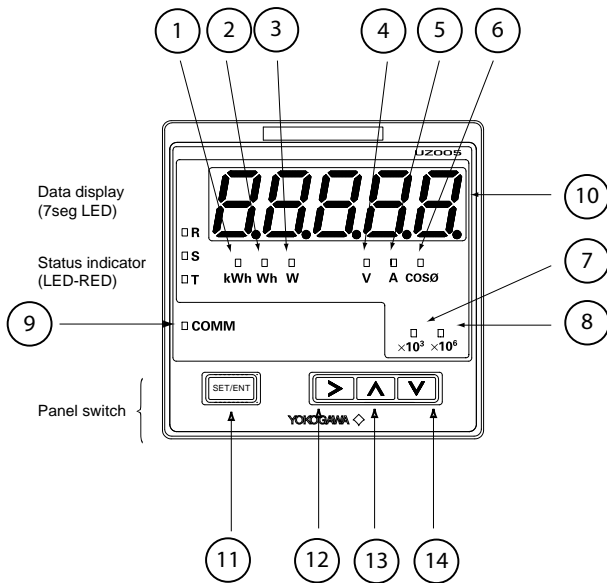

1 kWh (Integration)

Light on when data on Display Section is integrated power [kWh].

2 Wh (Optional Integration)

Light on when data on Display Section is optional integrated power [Wh].

3 W (Power)

Light on when data on Display Section is power momentary value [W].

4 V (Voltage)

Light on when data on Display Section is voltage momentary value [V].

5 A (Current)

Light on when data on Display Section is current momentary value [A].

6 cos ϕ

Light on when data on Display Section is power factor momentary value [cos ϕ].

7 X 10³

Light on when data value on Display Section is kilo unit. And light on when integrated power value is mega unit.

8 X 10⁶

Light on when data value on Display Section is mega unit.

9 COMM

Light on during communication (RS-485 communication) is made.

10 Display Section

Display measured value data, preset parameter symbol, set value data, adjustment parameter symbol, adjustment data and the like.

(1) Measurement items: integrated power, optional integrated power, power momentary value voltage momentary value, current momentary value, power factor momentary value

(2) Setting items: RS-485 station number, data transmission rate, lower limit of input range, upper limit of input range, PT ratio, CT ratio, integrating low cut power, integrating pulse unit (fixed point part, exponent), integrating pulse ON pulse duration

(3) Adjustment items: power momentary value input zero, power momentary value input span, voltage momentary value input zero, voltage momentary input span, current momentary value input zero, current momentary value input span, power momentary value input zero, power momentary value input span

11 SET/ENT Switch

This switch is used for changing over displays of screens and items. It is also used for registration of set values and adjusted values. Pressing the switch for 3 seconds or more changes over the displays for measured value, parameter setting, or input/output adjusting.

12 Range Switch

This switch is used for changing over display of phases. It is also used for shifting digit position and decimal position of set values on parameter setting display.

13 Figure UP switch

This switch is used for the followings:

1. Increase the set value on parameter setting display.
2. Display the maximum value of voltage or current.
3. Increase the adjusted value at input/output adjustment. I

14 Figure DOWN switch

This switch is used for the followings:

1. Parameter decrement at parameter setting.
2. Display the minimum value of voltage or current
3. Decrease the adjusted value at input/output adjustment

Schematic Diagram of Change-over Display Screen

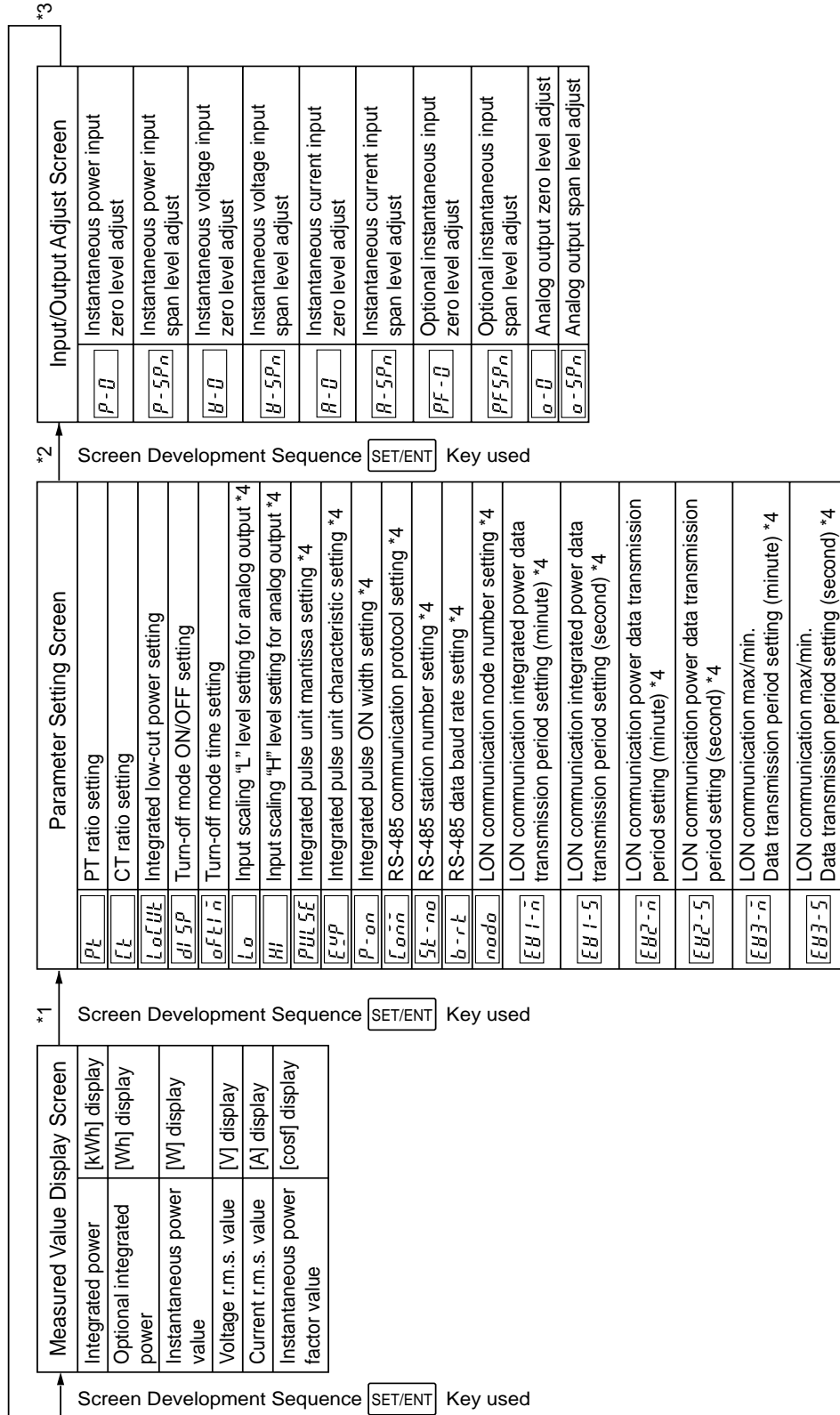

- *1: Press SET/ENT key till the PT Ratio Setting Screen is displayed.
- *2: Press SET/ENT key till the Instantaneous Power Input Zero Level Adjust Setting Screen is displayed.
- *3: Press SET/ENT key till the last MEASURED VALUE DISPLAY SCREEN is displayed.
- *4: By-passed if option is none.
- *: If no key operation continues during five minutes when INPUT/OUTPUT ADJUST DISPLAY SCREEN or PARAMETER SETUP DISPLAY SCREEN are displayed, the display screen changes to VALUE DISPLAY SCREEN and displays the last measured value.

■ Example of Parameter Setting Screen (PT Ratio Setting)

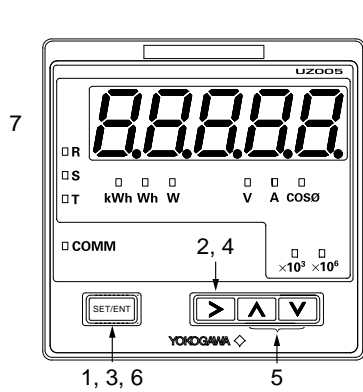

- 1 Display Setting Screen at pressing **SET/ENT** key within three seconds
- 2 Change decimal point position at pressing **>** key
- 3 Fixing decimal point position at pressing **SET/ENT** key
- 4 Change numeral column at pressing **>** key
- 5 Change numeral column at pressing **↑** and **↓** key
- 6 Fixing numeral value at pressing **SET/ENT** key
- 7 Light on and off of setting value.
- 8 If the setting is complete correctly, press **SET/ENT** key.
If required correcting, press any of **>** key, **↑** key, and **↓** key, then repeat from step 1.

■ Example of Communication Connection

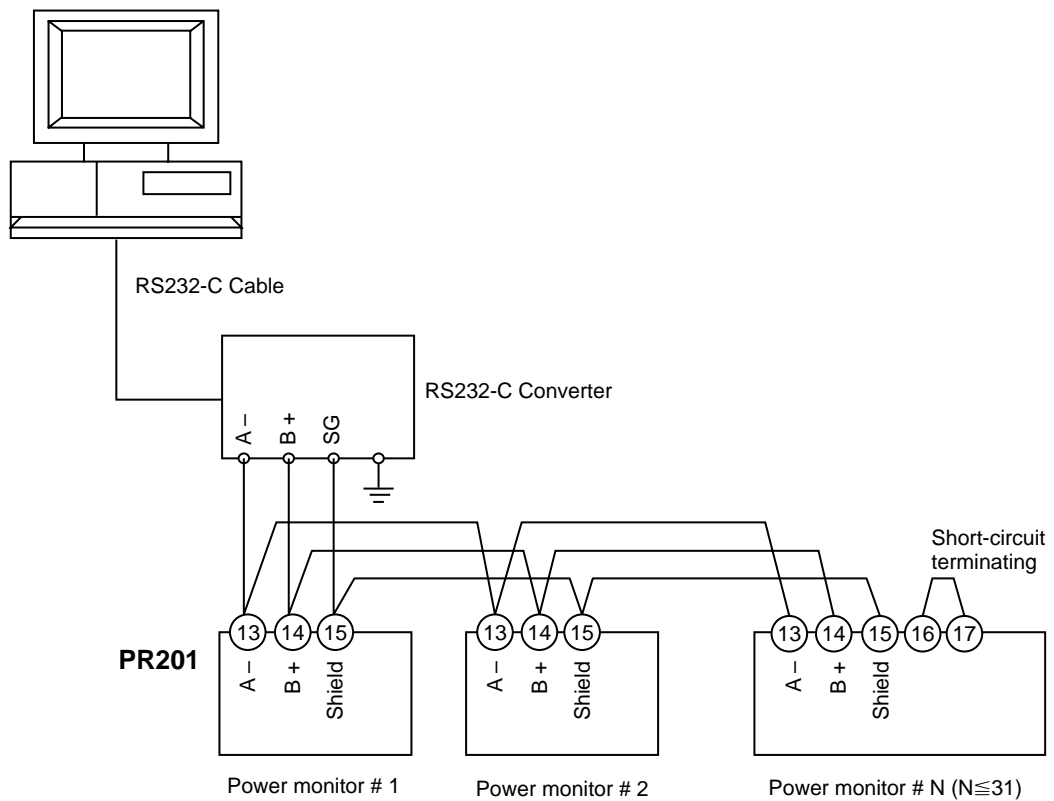

■ Specifications

● Input & Output Specifications

Input Specs.

Phase & wire system: 1-phase 2-wire system, 1-phase 3-wire system, 3-phase 3-wire system, 3-phase 4-wire system

Input frequency: 45 to 65Hz

Rated input voltage: 110V AC, 220V AC, 440V AC,
3-phase 4-wire system: 64V AC, 127V AC,
277V AC

Permissible Input voltage: 1.2 times of rated voltage
(continuous), 1.5 times (10 seconds)

Rated input current: 1A AC, 5A AC

Permissible Input current: 1.2 times of rated current
(continuous), 2 times (10 seconds),
10 times (3 seconds)

Input (power) measuring range (secondary side of PT, CT
when CT, PT are set)

● 1-phase 2-wire system

Input (AC)	RP	Input range	App. Consumed VA	
			Voltage	Current
110V/1A	100W	-120 to +120W	0.2VA	0.2VA
110V/5A	500W	-600 to +600W		
220V/1A	200W	-240 to +240W	0.4VA	
220V/5A	1000W	-1200 to +1200W		
440V/1A	400W	-480 to +480W	0.8VA	
440V/5A	2000W	-2400 to +2400W		

● 1-phase 3-wire system

Input (AC)	RP	Input range	App. Consumed VA	
			Voltage	Current
200V/1A	200W	-240 to +240W	0.2VA/ phase	0.2VA/ phase
200V/5A	1000W	-1200 to +1200W		

● 3-phase 3-wire system

Input (AC)	RP	Input range	App. Consumed VA	
			Voltage	Current
110V/1A	200W	-240 to +240W	0.2VA/ phase	0.2VA/ phase
110V/5A	1000W	-1200 to +1200W		
220V/1A	400W	-480 to +480W	0.4VA/ phase	
220V/5A	2000W	-2400 to +2400W		
440V/1A	800W	-960 to +960W	0.8VA/ phase	
440V/5A	4000W	-4800 to +4800W		

● 3-phase 4-wire system

Input (AC)	RP	Input range	App. Consumed VA	
			Voltage	Current
110V/1A	300W	-360 to +360W	0.2VA/ phase	0.2VA/ phase
110V/5A	1500W	-1800 to +1800W		
220V/1A	600W	-720 to +720W	0.4VA/ phase	
220V/5A	3000W	-3600 to +3600W		
64V/1A	200W	-240 to +240W	0.1VA/ phase	
64V/5A	1000W	-1200 to +1200W		
127V/1A	400W	-480 to +480W	0.2VA/ phase	
127V/5A	2000W	-2400 to +2400W		
277V/1A	800W	-960 to +960W	0.5VA/ phase	
277V/5A	4000W	-4800 to +4800W		

RP=Rated Power

When outer set of PT, CT, check to see the primary side input power is less than 10000 MW and the value calculated by the formula below is within above input measuring range list.

$$\text{Input range (W)} = \frac{\text{Primary side input power (W)}}{(\text{PT ratio}) \times (\text{CT ratio})}$$

Rated power factor: LEAD 0.5 to 1 to LAG 0.5

<Optional integrated control signal>

Input point: 1 point

Input signal: contact or voltage

	Contact signal	Voltage signal
ON signal	below 200‰	-1V DC, below 200‰
OFF signal	over 100k‰	4.5 to 25V DC

ON signal: Optional integration start (reset, integration start)

OFF signal: Optional integration stop

(Note) Control of optional integration can also be made through communication. Control by communication is once made, only control by communication is once made, only control by communication is made thereafter.

Integrated lowcut power: Integrated lowcut power below lowcut power is not made by integrated power, optional integrated power and integrated pulse output. Set integrated lowcut power for input to this instrument.

Parameter setting screen item	Setting range	Fixed decimal point
Integrated lowcut power	0.1 to 99.9W	0.5W when shipment

Output Specs.

Output point: 1 point (commonly used for analog and integrated pulse outputs)

<Analog Output>

Function: Conversion of output instantaneous power into DC current.

Output signal (instantaneous power): 4 to 20mA DC

Permissible load resistance: 0 to 750Ω

Input scaling: Indicates instantaneous power range to be converted. Input scaling can be set by "H" and "L" levels of analog output on parameter setting screen. Set "L" and "H" levels within measuring range of this instrument. Also set span (difference between "L" level and "H" level) so as it would be more than 50% of rated power. If not specified when ordering, it would be shipped "L" level at 0W, and "H" level at rated power (W).

<Integrated pulse output>

Function: Outputs pulse in proportion to integrated power

Output signal: Open collector

Output capacity: 200mA, 30V DC

Integrated pulse unit: Indicates actual kWh corresponding 1 pulse input to this instrument. It can be set through integrated pulse unit characteristic and mantissa sections on parameter setting screen.

Rated power	Setting range
100W	5.556 × 10 ⁻⁶ to 1.000 × 10 ⁻¹ kWh/pulse
200W	
300W	
400W	
500W	
600W	
800W	
1000W	6.667 × 10 ⁻⁶ to 1.000 × 10 ⁻¹ kWh/pulse
1500W	1.000 × 10 ⁻⁵ to 1.000 × 10 ⁻¹ kWh/pulse
2000W	1.334 × 10 ⁻⁵ to 1.000 × 10 ⁻¹ kWh/pulse
3000W	2.000 × 10 ⁻⁵ to 1.000 × 10 ⁻¹ kWh/pulse
4000W	2.667 × 10 ⁻⁵ to 1.000 × 10 ⁻¹ kWh/pulse

(Note) When power OFF, integrated power on display is maintained. As for integrated pulse output, error of less than 1 pulse of integrated power arises.

Integrated pulse ON pulse width: Indicates ON time of pulse to output. It can be set on parameter setting screen. Set it so as not to exceed maximum ON pulse width obtained by the formula below:

Maximum On pulse width (ms)

$$= \text{pulse unit [kWh/pulse]} \times 3600 \times 1000^2 \cdot 10^{-10} \text{ rated power [W]} \times 1.2$$

Setting range	Remarks	Initial value if not specified
10 to 1270ms	Set at 10ms unit	50ms

● Communication Output specs.

Output point: 1 point (Commonly use for RS-485 and LON communications)

Function: Refer "Communication Output"

● Standard Performance

Accuracy rating: Instantaneous power, voltage r.m.s. value, current r.m.s. value ±0.5% of rated value (at 23°C±2°C)
(Equivalent JIS C 1102 0.5 grade)
Integrated power energy
±(Power measuring accuracy+0.5% of rdg) (at 23°C±2°C)
Power factor
±2% of rated value (at 23°C±2°C)
Analog output
±0.5% of span (at 23°C±2°C)
(Equivalent JIS C 1111 0.5 grade)
However, ±1% of span in case span is 50 to 80% of rated power.

Optional integration function: This function integrates power energy during the time optional integration starts to operate and display it by digital. There are 2 methods to control optional integration, one is made through optional integrating control signal and the other is made through communication. When optional integration control is made through communication, optional integration control signal thereafter becomes invalid. Therefore, make control through either one of the above 2 methods. When optional integration changes over from stop to start, integration starts after optional integrated power is reset.

Backup when power off (power meter): Integrated power holds last integrated value when power off. Optional integration has not this function.

Response speed of instantaneous power (analog output): Within 1 second (until enter into ±1% of last value)

Up date of transmit data: Power, voltage, current, power factor within 500ms

Insulation resistance: 100MΩ (500V DC) between any two points of voltage input, current input, optional integrated control signal, output, communication output, power supply and ground

Withstand voltage: 2000V AC/minute between any two points of voltage input, current input, output, power supply and ground 2000V AC/minute between communication output and (input, power supply) 1000V AC/minute between communication output and (output, ground).

500V AC/minute between optional integrated control signal and (input, output, communication output, power supply and ground)

Impulse withstand voltage: 5kV (1.2/50μs) between input and output, input and ground, power supply and ground

Temperature range: -10 to 55°C

Humidity range: 5 to 90% RH (no condensation)

Effect of power supply voltage fluctuation: ±0.3% of RV (instantaneous value)/85 to 264V AC
±1.0% of RV (power factor)/85 to 264V AC

Effect of temperature change: ±0.5% of RV (instantaneous value)10°C
±2.0% of RV (power factor)/10°C

Effect of input frequency: ±0.3% of RV (instantaneous value)/45 to 65Hz
±1.0% of RV (power factor)/45 to 65Hz
(RV=Rated Value)

Power voltage: 85 to 264V AC, 45 to 65Hz

Power dissipation: 6VA (at 100V AC)
8VA (at 200V AC)

● Display Operation

PT ratio CT ratio:

Setting of PT and CT ratio makes display converting input of this instrument into primary side input value of PT and CT.

Setting can be done on parameter setting screen.

PT ratio setting range	CT ratio setting range
1 to 32000	0.05 to 32000

Integrated power:

□□□□□[kWh] or □□□□□[MWh]

(w/o symbol, partially fixed decimal point integer 5 digits)

Input power rating x PT ratio x CT ratio	Display, decimal point
30W to 99999kW	0 to 99999kWh
100kW to 999.99kW	0.00 to 999.99MWh (kWh+10 ³)
1MW to 9.9999MW	0.0 to 9999.9MWh (kWh+10 ³)
10MW over	0 to 99999kWh (kWh+10 ³)

Inegrated power data is reset to zero when the data exceed maximum display value.

Optional integrated power:

□□□□[Wh] (w/o symbol, integer 5 digits)

Instantaneous power:

±□□□.□[W] to ±□□□□[MW] (w/symbol, floating decimal point 4 digits, minimum resolution:0.1W)

Voltage r.m.s. value:

□□□.□[V] to □□□□[kV] (w/o symbol, floating decimal point 4 digits, minimum resolution:0.1V)

Current r.m.s. value:

□.□□□[A] to □.□□□[kA] (w/o symbol, floating decimal point 4 digits, minimum resolution:0.001A)

Voltage maximum value:

—□□□.□[V] to —□□□□[kV] (w/o symbol, floating decimal point 4 digits, minimum resolution:0.1V)

Voltage minimum value:

—□□□□[V] to —□□□□[kV] (w/o symbol, floating decimal point 4 digits, minimum resolution:0.1V)

Current maximum value:

—□.□□□[A] to —□.□□□[kA] (w/o symbol, floating decimal point 4 digits, minimum resolution:0.001A)

Instantaneous power factor:

d□.□□□ to 1.000 to G□.□□□[COSφ] (w/o symbol, fixed decimal point 4 digits, minimum resolution:0.001COSφ, d:Lead, G:Lag)

kWh LED: Light on during display of integrated power [kWh].

Wh LED: Light on during display of optional integrated power [Wh].

W LED: Light on during display of instantaneous power [w].

V LED: Light on during display of voltage r.m.s. value [V].

A LED: Light on during display of current r.m.s. value [A].

COSφ LED: Light on during instantaneous power factor [COSφ]

X10³ LED: Light on when displaying instantaneous value is kilo unit. Or light on when integrated power [kWh] is Mega unit.

X10⁶ LED: Light on when displaying instantaneous value is mega unit.

COMM LED: Green light on when RS-485 or LON communication. As for LON communication, red light on and off when network parameter is under construction, and red light on when communication trouble or service.

SET/ENT Switch: This switch changes-over display of integrated power, optional integrated power, instantaneous power, voltage r.m.s. value, current r.m.s. value and instantaneous power factor. Also, it selects parameter setting item and input/output adjust item.

R, S, T (phase indicator)

Light on phase that the data is displayed in data display.

Current display: R, S, T

Voltage display: R-S, S-T, T-R

R, S, T (3-phase 4-wire system)

➤ (Range switch)

This switch is used for display line change-over, and for movement column position of setting data and decimal point position.

▲ (Numeric up switch)

This switch is used for increment of setting parameter and input/output adjustment data.

▼ (Numeric down switch)

This switch is used for decrement of setting parameter and input/output adjustment data.

Note 1: Instantaneous power value is displayed with symbol in case only negative.

Note 2: When display of maximum value, '—' is displayed at the top with light on and off.

Note 3: When display of minimum value, '—' is displayed at the top with light on and off.

Note 4: Instantaneous power factor is displayed only when measuring option is designated.

● Communication Output

RS-485 or LON communication outputs can optionally be selected

<Communication data>

Following measuring value can be read out by converting input into PT•CT primary side input.

- Integrated power
- Optional integrated power (present value)
- Optional integrated power (last value)
- Instantaneous power
- Voltage r.m.s. value
- Current r.m.s. value
- Instantaneous power factor or Current 2 r.m.s. value
- Voltage maximum value
- Voltage minimum value
- Current maximum value
- Current 2 maximum value

Also, start•stop of optional integrated power and reset of maximum and minimum values of voltage r.m.s. value and maximum value of current r.m.s. value can be done through communication.

<RS-485 Communication>

Function: Various measuring values can be read out through personal computer by command/ response mode. Readout of measuring value would be made individually or in block.

Also, control of optional integration and initialization of maximum and minimum values can be done through personal computer.

System Configuration:

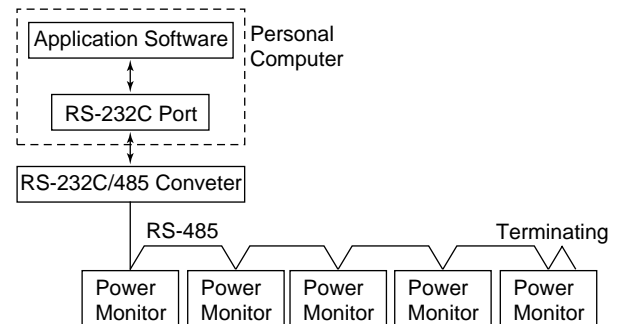

Note: RS-232C/485 Converter is recommended to use our ML1 in AUTO mode.

Communication specs.: RS-485 Interface

Transmit distance: Maximum about 1.2km

(When use of 24AWG twist pair cable)

Connection mode:

- (1) RS-485 standard Multi-drop connection
Maximum 32 stations (including upper personal computer)
- (2) Terminating resistor: 120Ω
(ON by terminal short)
- (3) Not insulated with inner circuit

Connecting Terminal: 3 terminals back face

- A: Balanced type twist pair cable –
- B: Balanced type twist pair cable +
- C: Shield

Transmit mode: Half duplex communication

Synchronizing mode: Start-stop synchronization

Transmit speed: Can be set through parameter setting screen

Setting Range
9600 / 4800 / 2100 / 1200

Data format: Start bit 1 bit

Data bit 8 bits

Parity None

Stop bit 1 bit

Error detect: SUM CHECK (simply adding 2 bytes)

Xon/Xoff Control: None

Terminating character designation: Yes (CR)

Station number setting: Can be set through parameter setting screen

Setting range
1 to 31

Communication error disposal: If data received is other than command, reading is ignored and no disposal be made. (noise or erroneous data would be ignored).

Make time-out disposal through upper computer.
Set time-out time more than 1 second.

<LON Communication>

Function: Measuring data can be simply read out on personal computer through LON communication adapter and DDE: server without consciousness of communication. Also, control of optional integration and initialization of maximum and minimum values can be done through personal computer. Please contact us as to connection with other instruments.

System Configuration:

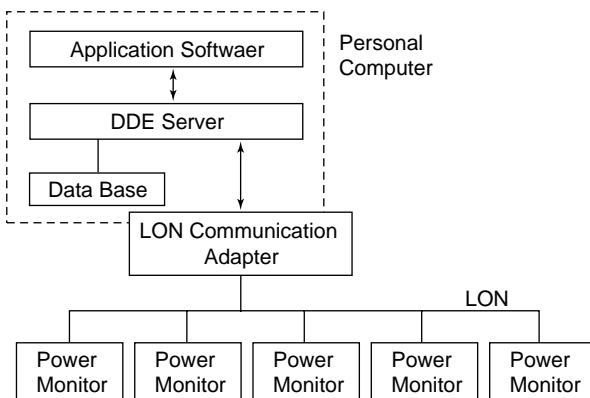

● **Shape & Mounting**

External dimension: 110 x 110 x 111mm (HxWxD)

Mounting method: Panel mouting

(Refer panel cut dimension)

Material:

Case: uninflamable ABS plastic (black)

Terminal board: uninflamable ABS plastic (black)

Weight: Abt 500g

Connecting method: M3 screw terminal connection (output, communication, optional integrated control signal)
M4 screw terminal connection (input, power supply)

● **Accessories:**

Label...2, Nut M5...2, Washer M5...2 Spring washer M5...2 Short bar...1

YOKOGAWA

Yokogawa Electric Corporation

YOKOGAWA ELECTRIC CORPORATION

Network Solutions Business Division

2-9-32, Nakacho, Musashino-shi, Tokyo, 180-8750 JAPAN

Phone: +81-422-52-7179 Facsimile: +81-422-52-6793

Sales Branch Offices

Tokyo, Nagoya, Osaka, Hiroshima, Fukuoka

YOKOGAWA CORPORATION OF AMERICA

Headquarters

2 Dart Road, Newnan, GA. 30265-1094 U.S.A.

Phone: +1-770-253-7000 Facsimile: +1-770-251-0928

Sales Branch Offices / Texas, Chicago, Detroit, San Jose

YOKOGAWA EUROPE B. V.

Headquarters

Databankweg 20, 3821 AL Amersfoort THE NETHERLANDS

Phone: +31-334-64-1611 Facsimile: +31-334-64-1610

Sales Branch Offices / Houten (The Netherlands), Wien (Austria), Zaventem (Belgium), Ratingen (Germany), Madrid (Spain), Bratislava (Slovakia), Runcorn (United Kingdom), Milano (Italy), Vélizy Villacoublay (France), Johannesburg (Republic of South Africa)

YOKOGAWA AMERICA DO SUL S.A.

Headquarters & Plant

Praca Acapulco, 31-Santo Amaro, Sao Paulo/SP, BRAZIL CEP-04675-190

Phone: +55-11-5681-2400 Facsimile: +55-11-5681-4434

YOKOGAWA ENGINEERING ASIA PTE. LTD.

Head office

5 Bedok South Road, Singapore 469270 SINGAPORE

Phone: +65-6241-9933 Facsimile: +65-6241-2606

YOKOGAWA ELECTRIC KOREA CO., LTD.

Seoul Sales office

395-70, Shindaebang-dong, Dongjak-gu, Seoul, 156-010, KOREA

Phone: +82-2-3284-3000 Facsimile: +82-2-3284-3019

YOKOGAWA TAIWAN CORPORATION

Head office

17F, No.39, Sec. 1, Chung Hwa Road Taipei, 100 TAIWAN

Phone: +886-2-2314-9166 Facsimile: +886-2-2314-9918

YOKOGAWA AUSTRALIA PTY. LTD.

Head office

Centre Court D1, 25-27 Paul Street North, North Ryde, N. S. W. 2113, AUSTRALIA

Phone: +61-2-9805-0699 Facsimile: +61-2-9888-1844

YOKOGAWA INDIA LTD.

Head office

40/4 Lavelle Road, Bangalore, 560 001, INDIA

Phone: +91-80-227-1513 Facsimile: +91-80-227-4270

LTD. YOKOGAWA ELECTRIC

Grokholskiy per. 13, Build. 2, 4th Floor, 129010, Moscow, RUSSIA FEDERATION

Phone: +7-095-737-7868 Facsimile: +7-095-737-7869
